

Panel Socket

Panel Socket DIN 7/16

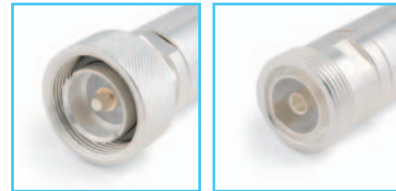

716M-PANF-B0

716F-PANF-B0

PRODUCT FEATURES

- Customising possibilities
- 10-year comprehensive warranty
- No need for tape or other external weatherproofing
- IP68-classified and water-pressure proof tested down to 25 m
- Designed to maintain high pressure on contact surfaces to reduce intermodulation

COMMON FOR BOTH

CONNECTOR OPERATING FREQUENCY	0 - 7500 MHz
VSWR / RETURN LOSS	
0 - 2000 MHz	1.036 / -35 dB
0 - 2500 MHz	1.065 / -30 dB
INTERMODULATION*	
2 x 20 W transmitter	< -156 dBc
OPERATING TEMPERATURE	-55 °C to +80 °C
DIMENSIONS	
H x W x D	21 x 32 x 32 mm (0.86 x 1.25 x 1.25 in)

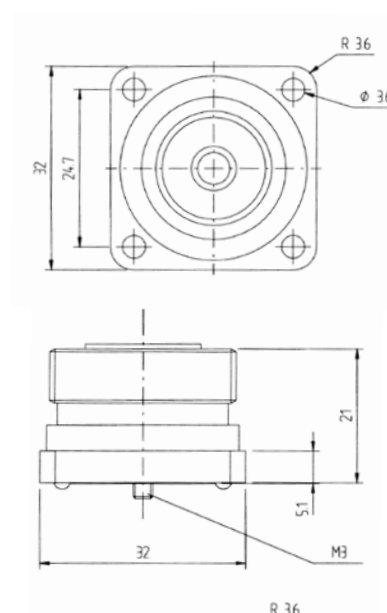

ARTICLE	716M-PANF-B0	716F-PANF-B0
CONNECTOR	DIN 7/16 male	DIN 7/16 female

* During intermodulation measurement attached cables are exposed to shock and vibration.